



HEADLAMP ALIGNER MODEL HLA2400 OPERATORS MANUAL

**TES1295/D
Feb 2013**

IMPORTANT

Every reasonable effort has been made to ensure that information within these Operating Instructions is correct at the time of release, but Crypton cannot accept responsibility for any errors that may occur.

The information in these Operating Instructions is subject to change without notice, and does not represent a commitment on the part of Crypton.

Service & Warranty

The reliability of this equipment is fully supported by Crypton. Please refer to the section titled 'After Sales Service' for full details.

Software Licence

Further to our general Terms & Conditions of Sale, the software described in these Operating Instructions is furnished under the following Software Licence Agreement:

1. Licence: You may use the program on the machine provided. You may not copy, duplicate or transmit the program in any form, in whole or in part, without the express prior written permission of Crypton.
2. Term: The licence is effective until terminated. You may terminate the licence by destroying the program together with all copies, or returning the program to Crypton.
3. Crypton does not warrant that the program will meet your requirements or that its operation will be uninterrupted or error free.
4. In no event will Crypton be liable to you for any incidental or consequential damages, including lost profits, business operation and the like, arising out of the use or inability to use this program

You acknowledge that you have read this Agreement, understand it, and agree to be bound by its provisions.

CONTENTS

	Page
INTRODUCTION	4
SAFETY	4
RECEPTION	5
INSTALLATION	6
LOCATION	6
RAILS	6
OPERATIONS ON A VEHICLE	7
GENERAL	7
MOT TEST PROCEDURE	8
INTENSITY METER	9
MAINTENANCE	10
CLEANING	10
CALIBRATION	10
DISPOSAL	10
SPECIFICATION	10
AFTER SALES SUPPORT & HELPLINES	11
SERVICE/REPAIRS	11
TECHNICAL INFORMATION	11
AFTER SALES SERVICE	12
ON SITE SERVICE/OVERHAUL/SPARE PARTS	12
OVERSEAS	12
FULLY COMPREHENSIVE AFTER-SALES SERVICE	12

INTRODUCTION

The Headlamp Aligner HLA2400 is designed to check the setting of main and/or dipped beams of cars, motorcycles and commercial vehicle headlamps.

The range of height adjustment allows measurement on headlamps that have centre to ground distances between 240 and 1500 mm.

SAFETY

Read and fully understand these safety instructions before using the aligner

Do not allow unauthorised operators to use this equipment

Tests may be performed with the engine running, in this case always use an exhaust extractor.

Put the handbrake on and select neutral or park

Do not use the unit in direct sunlight .

Keep the unit in a position where temperature changes are a minimum and condensation does not take place.

RECEPTION

Unpack the unit and identify all parts. Check these against the following diagram and if any parts are missing, immediately inform your supplier.

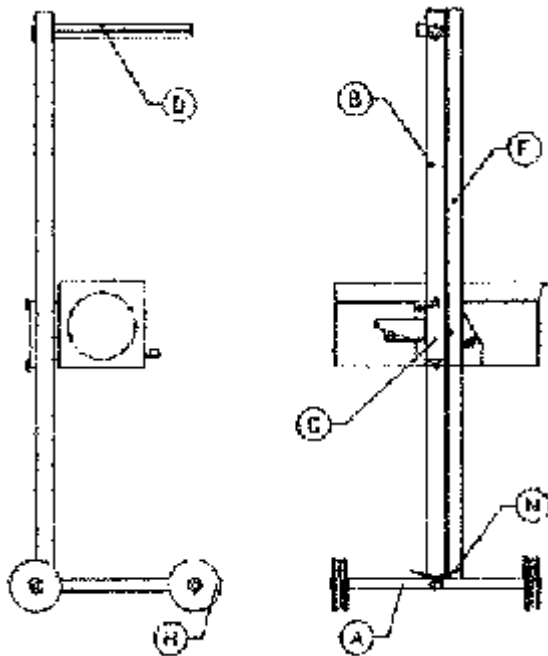

- A - Base
- B - Column
- C - Vertical clamping mechanism
- D - Mirror or visor
- E - Optical system
- F - Spring protection
- H - Wheels
- N - Brake

Fit the mirror visor to the column using the screws provided.

Rails: Standard unit is supplied with 4 rail sections for ease of packing and these should be fitted as described in the installation section.

HGV versions are supplied with 6 rail sections to provide the longer running track required in this application.

INSTALLATION

LOCATION

The working area where the aligner is to be used and the test vehicle parked must be as flat and level as possible. The maximum slope of the area should not exceed 0.5% and the area should all be at the same slope.

The Headlamp Aligner is an optical instrument that contains a lens. Avoid locations where sunlight can fall directly on the lens of the unit. If this cannot be achieved, then the lens must be covered with a dark cloth when not in use.

RAILS

Four rails are supplied with the standard unit (six with HGV) and these must be fitted to create two parallel tracks at right angles to the vehicle axis. The peaks of the rails should be set precisely 394mm apart and in a position that will mean the lens of the unit will be between 200 and 500mm from the headlamp under test.

Fit the rails to the floor using screws and plugs in the normal way. Before fully tightening the screws, shim up so that the difference in level end to end and rail to rail does not exceed 2mm.

Important: Where this equipment is used for vehicle testing under the MOT scheme in the UK. It must be sited and installed in accordance with the VOSA requirements. This is the customer's responsibility.

OPERATIONS ON A VEHICLE

GENERAL

Before testing the headlamp aim it is important that the vehicle is prepared so the accurate results can be obtained.

The vehicle should be positioned squarely in the test area with the front wheels pointing straight ahead and in a position such that the headlamp glasses are between 200-500mm from the aligner lens. Closer spacing is acceptable on complex headlights.

Tyre pressures should be correct and the headlamp lenses clean and dry. Ensure also that the vehicle is not unevenly loaded .

Set the aligner in front of the first headlamp.

Test the rotational alignment of the unit by looking into the visor mirror.

Check that a horizontal part of the car (the corners of the windscreen or bonnet) are parallel to the line drawn on the visor. If not unlock the column by using the foot pedal and rotate the column until the image is parallel, then lock in position.

Measure from the floor to the centre of the headlamp and position the unit to the same height using the scale on the column. A tolerance of +/- 30mm is acceptable for this setting.

Look into the top of the unit and observe the spirit level which should show absolutely level, if not adjust - see CALIBRATION.

Follow the beam checking procedure defined below under MOT procedure.

MOT TEST PROCEDURE

- 1) Drive the test vehicle squarely up to the aligner and bring the car to rest with the headlamp lens between 200 and 500mm from the lens of the aligner. Closer spacing is acceptable with complex headlights.
- 2) Azimuth setting:

Either: Look into the visor mirror and check that a horizontal part of the car (the corners of the windscreen or bonnet) are parallel to the line drawn on the visor. If not, unlock the column by using the foot pedal and rotate the column until the image is parallel then lock in position.

Or: Select two points on the vehicle, parallel with the front to back axis. For motorcycles, two points on the centreline, one at the front and one at the back, can normally be located.

For private cars, a suitable method is to determine the centre of the front and rear windows and fix a strip of tape to each.

On commercial vehicles use the straight line of the side of the vehicle.

Raise or lower the aligner until the selected points can be viewed over the back sight on top of the aligner box. If the front sight does not also line up then operate the foot pedal to unlock the column and rotate it until all four points are in line.

Then relock column using other foot pedal.

- 3) Set the aligner height:

Measure the distance from the floor to the centre of the headlamp to be tested and set the aligner box to this height using the scale on the column.

- 4) Set the aligner left/right position

Start with the right hand headlamp and move the aligner along the track until the front and rear sights on the aligner box line up with the centre of the lamp to be tested.

Switch on the lamp and verify the spirit level reads correctly, adjust if not level.

5) Alignment check

The screen inside the equipment is viewed through the tinted top window and is a scaled down reproduction of a test screen placed at a distance of 10m from the vehicle and at least 3m wide.

The Tester's manual appropriate to the vehicle being tested should be consulted to determine whether the headlamp should be set to main or dip beam.

Switch on the headlamps and select dipped or main beam as appropriate.

Observe the light pattern displayed on the screen. This should be checked for the headlamp type under test by reference to the Tester's manual.

INTENSITY METER

To produce maximum light output the engine should be running while taking readings on the luxmeter. It is advisable to rev the engine to about 2000rpm after starting to ensure the alternator is cut-in and producing its full output.

Switch headlamps on and select high beam.

When testing a slow speed vehicles or motorcycle the meter should indicate near the GOOD/BAD position on the top scale.

Normal tungsten lamps should indicate in the centre of the GOOD area.

Halogen or iodine lamps should give a deflection above GOOD into the HALOGEN area.

Select low beam and check deflection on the lower scale.

Switch off lights and stop engine after test.

MAINTENANCE

CLEANING

When not in use the unit should be covered to stop dust accumulation, a cover is available.

Use only non abrasive detergents and water when cleaning the equipment, do not use alcohol.

Do not oil the column as the clamping device relies on friction.

CALIBRATION

The unit should provide trouble free operation for a long period provided the level is checked and the unit is aligned correctly with the vehicle.

Check the level by observing the spirit level inside the optical box. If not level, adjust the position of the box on its brackets after slackening the mounting nuts. Retighten the nuts and recheck after adjustment.

Full calibration of the unit can be provided by our service agents - see contact details at the end of this manual.

DISPOSAL

The majority of the unit is steel and this should be disposed of in the normal way.

Glass (the lens), plastics (wheels, cover, handles etc.) and a few copper wires make up the small percentage of the total mass.

SPECIFICATION

Height	-	1770 mm
Width	-	610 mm
Depth	-	610 mm
Max measuring height	-	1500 mm
Min measuring height	-	240 mm
Focal length	-	500 mm
Rail length	-	3700 mm (4500 mm HGV)

AFTER SALES SUPPORT & HELPLINES

SERVICE/REPAIRS

There are no user serviceable parts inside the equipment. If the unit requires attention or repair please return it to the address below, ensuring that you provide all information requested.

Service Centre
CRYPTON
Hopton Industrial Estate
London Road
Devizes
Wiltshire
SN10 2EU
Tel: +44 (0) 844 665 7610
Fax: +44 (0) 844 665 7604
Email: support@cryptontechnology.com

Please include the following:

- Name of person returning the unit
- Name, address and telephone number of garage/organisation
- Full description of the problem

The returned unit will be examined and the sender notified of the cost before any repair work is undertaken.

TECHNICAL INFORMATION

Crypton provide information and contracts covering:

- Fault code information
- Diagnostic information
- Car data
- Software support contracts & updates
- Accessories

AFTER SALES SERVICE

Apart from the routine maintenance and adjustments stipulated in this manual the equipment must not be tampered with in any way. All further servicing must be carried out only by an engineer from an Authorised Agent. Failure to observe these conditions will invalidate the Guarantee.

ON-SITE SERVICE / OVERHAUL / SPARE PARTS

If you require a Service Engineer to attend ON SITE, either due to an equipment fault, or for machine calibration, or if the equipment covered by this manual requires to be sent back for factory overhaul, or if you need spare parts, please contact our Product Support Helpline at the following number.

Tel: +44 (0)844 665 7610

Fax: +44 (0)844 665 7604

Email: support@cryptontechnology.com

OVERSEAS

Service abroad is provided by the agent from whom your equipment was purchased.

FULLY COMPREHENSIVE AFTER-SALES SERVICE

Call Crypton Helpline for details of local service agents.

Tel. +44(0)844 665 7610

Crypton Ltd. Hopton Industrial Estate, London Road, Devizes, Wiltshire SN10 2EU

Tel: +44 (0)844 665 7613

Fax: +44 (0)844 665 7604

Email: sales@cryptontechnology.com

Website: www.cryptontechnology.com