

Jacking Beam Class 4

CJB640 Series

Operating Instructions

TES1516/B



Contents

Foreword	3
Record of installation	5
Record of hand over.....	6
1.Introduction	7
1.1 Installation and check of the axle lift	7
1.2 Information of Warning.....	7
2. Master document of the Jack	8
2.1 Manufacturer.....	8
2.2 Application	8
2.3 Changes at the construction	8
2.4 Displacement of the axle-lift.....	8
2.5 Crypton statute of conformity	9
3. Technical Information	10
3.1 Technical ratings.....	10
3.2 Safety device.....	10
3.3 Data sheet	11
3.4 Hydraulic-Pneumatic diagram	12
4. Safety regulations	13
5. Operating instructions	13
5.1 Lifting the vehicle.....	13
5.2 Lowering the Jack	14
6.Troubleshooting	14
7.Inspection and Maintenance	15
7.1 Maintenance plan of the lift	15
7.2 How often must the lift be cleaned?.....	16
8. Security check	17
9. Installation.....	18
9.1 Regulations of installation	18
9.2 Initiation	18
9.3 Changing the installation place	18
First security check before installation	20
First security check before installation	21
First security check before installation	22
First security check before installation	23
First security check before installation	24
First security check before installation	25



Foreword

CRYPTON LIMITED-products are a result of long-standing experiences.

The high quality and the superior concept guarantee them reliability, a long lift time and the economic business.

To avoid unnecessary damages and dangers, read the operating instruction and observe the contents.

This equipment should only be used for its intended purpose.

Crypton Limited is not liable for any resulting damages. The user carries the risk alone.

Obligations of the user

- To observe and adhere to the operating instructions.
- To follow the recommended inspection and maintenance procedures and carry out the prescribed tests.
- The operating instructions must be observed by all persons working with or around the lift.
- Above all chapter 4 "Safety Regulations" is very important and must be closely adhered to.
- In addition to the safety regulations stated in the operating instructions manual, the appropriate safety regulations and the operating procedures of the place of operation must also be considered.

Obligations of the operator

The operator is obliged to allow only those persons complying to the following requirements to work with or around the unit.

- Persons being familiar with the basic regulations concerning labour safety and accident prevention and being trained to operate the particular unit.
- Persons having read and understood the chapter concerning safety and warning symbols.
- Persons using the lift are required to confirm that they have read and understood the chapter on safety and warning symbols by signing the appropriate form.

Dangers when operating the lift

CRYPTON LIMITED-Lifts are designed and built according to technical standards and the approved regulations for technical safety. The use of Crypton lifts for purposes other than those for which they were designed, may result in injury or even death.

The lift must only be operated :

- For its appropriate use
- In faultless condition concerning technical security.



Organisational Requirements

- The instructions for use are to be kept at the place of operation being easily accessible at any time.
- In addition to the instructions for use, rules pertaining to other regulations i.e. accident prevention and environmental rules are to be observed and adhered to.
- The owner of the Crypton lifting system must ensure that operators and persons working with or around the lift occasionally conduct “refresher” courses to ensure that the appropriate operating procedures and safety precautions are known.
- Personal Protective Equipment (PPE) must be used according to the appropriate regulations.
- All safety and danger signs on and around the lift are to be observed and followed!
- Spare parts must comply with the technical requirements specified by the manufacturer.
This is only warranted with original parts.
- Observe and adhere to the specified time intervals between tests and inspections.

Maintenance works, repairing faults

- Adjustments, maintenance, and inspections, are to be followed according to the time intervals specified. Details regarding the exchange of parts and components as mentioned in the operating instructions are to be adhered to.
These works must only be carried out by qualified personal.
- After maintenance- and repair works loose screws, nuts and bolts must always be firmly tightened!

Guarantee and liability

- Our “Terms and Conditions of Sale” are in force.
There will be no guarantee or liability for incidents involving injuries or death or damage to equipment if these incidents are the result of one or more of the following reasons.
- Inappropriate use of the lift
- Inappropriate installation, initiation, operation and maintenance of the lift.
- Use of the lift while one or several security devices do not work, do not work correctly or are not installed correctly.
- Failure to follow the regulations of the operating instructions regarding transport, storage, installation, initiation, operation and maintenance of the lift.
- Unauthorised changes to the structure of the lift without the prior written authority of Crypton Limited.
- Unauthorised changes of adjustments of important components of the lift (e.g. driving elements, power rating, motor speed, etc)
- Wrong or incorrect maintenance practice.
- Catastrophes, acts of God or external reasons.



Filling out and undersigned and copying this sheet and send the original to the lift manufacturer. The copy remains in the Manual.

**Crypton Limited
Hopton Industrial Estate
London Road
Devizes
Wiltshire
SN10 2EU**

Record of installation

The Jack CJB640 with the

serial number:..... was installed

on:.....

at the premises of:.....

address:.....

the safety was checked and the lift was started.

The installation was approved by the operating authority/competent person (please delete as applicable).

The safety of the axle lift was checked from the competent person before the initial operation.

.....
date	name of the operating authority	signature of the operating authority

.....
date	name of the competent person	signature of the competent person

Your customer service contact is:

.....



Record of handover

The Jacking Beam CJB640 with the

serial number:..... was installed
on:.....

at the firm:.....
address:.....

The safety was checked and the lift was started.

The persons below were introduced after the installation of the axle lift. The introduction was carried out by an installer of the lift-manufacturer or by a franchised dealer (competent person).

.....
date name signature

.....
date name signature

.....
date name signature

.....
date name signature

.....
date name signature

.....
date name signature

.....
date name of competent signature of the competent

Your customer service:.....

1.Introduction

The document **"Operating Instructions and Documentation"** contains important information about installation, operation and maintenance of the axle lift.

As proof of the correct **installation of the axle lift** the form "Record of Installation" must be signed and returned to Crypton Limited.

A copy of the form used to document the checks should be retained with this document.

Any **Change to the construction** and/or **displacement** of the axle lift must be registered in the **"Master document"** of the lift.

1.1 Installation and check of the axle lift

Only specialist staff are allowed to do work concerning safety and to do the safety checks of the lift. They are called experts and competent person in this document.

Experts are persons (for example self-employed engineers, experts), which have received instruction and have experience to check and to test axle lifts. They know the relevant labour and accidents prevention regulations.

Competent person are persons who have acquired adequate knowledge and experience with axle lifts. They took part in training from the lift-manufacturer (servicing technicians of the manufacturer or dealer, are competent)

1.2 Information of Warning

To show danger and to show important information the three symbols below are used. Pay attention to those passages, which are marked with these symbols.



Danger! This sign indicates danger to life. Incompetent handling of the described operation may be dangerous to life.



Caution! This sign cautions against possible damage to the axle lift or other material defects in case of incompetent handling.



Attention! This sign indicates for an important function or other important notes.



2. Master document of the Jack

2.1 Manufacturer

Crypton Limited
Hopton Industrial Estate
London Road
Devizes, Wiltshire, SN10 2EU

2.2 Application

The axle lift Jack CJB640 is a special lifting stage for lifting motor vehicles at the axle of the Vehicle or the pick up points. The max allowable axle load is 2000 kg.

2.3 Changes at the construction

Changes at the construction, expert checking, resumption of work (date, kind of change, signature of the expert)

.....
.....
.....
.....
.....
.....
.....

name, address of the expert

..... signature of the expert
place, date

2.4 Displacement of the axle-lift

Displacement of the axle-lift, expert checking, resumption of work (date, kind of change, signature of the competent person)

.....
.....
.....
.....
.....
.....

name, address of the competent person

..... signature of the competent person
place, date



2.5 Crypton Declaration of Conformity



Conformity explanation

in accordance with machine guideline 98/37/EG appendix 2

Company:

Crypton Limited
Hopton Industrial Estate
London Road
Devizes
Wiltshire
SN10 2EU

declares that the product

Lifting platform: CJB640

Order -, Serial number:

To which this explanation refers, agrees to the following standards and normative documents:

1. EN 1493 vehicle lifting platforms
2. DIN EN of 292 parts of 1 and 2 security of machines, fundamental ideas, general Organisation sets
3. EN 60 204/DIN VDE0113 electrical equipment of industrial machines
4. EN 954-1 security parts of controls, safety referred to machines -

We insure hereby that the certificate procedure was accomplished exclusively in accordance with the guideline 98/37/EG (22.06.1998), guideline of the advice for the adjustment of the legislation of the member states for machines and that the regulations of the standard DIN EN45014 general criteria for conformity explanation were considered by offers with the exhibition of the conformity explanation.

City, date

Signature



3. Technical Information

3.1 Technical ratings

Lifting capacity:	2000 kg
Lifting capacity of one carrying arm	1000 kg
Lifting time	20 sec without load / 35 sec with load
Lowering time	15 sec without load / 7 sec with load
Max. height	370 mm
Pneumatic pressure	min. 6 bar – max. 10 bar
Oil Tank	0,6 Litre
Sound level	84 dB (A)

3.2 Safety device

1. Click and pawl arrangement
Safety device of the load against unintentional lowering
2. Lowering valve
Slow lowering of the lift if the pipe breaks
3. Overprint valve
Overprint-safety of the hydraulic system

3.3 Data sheet

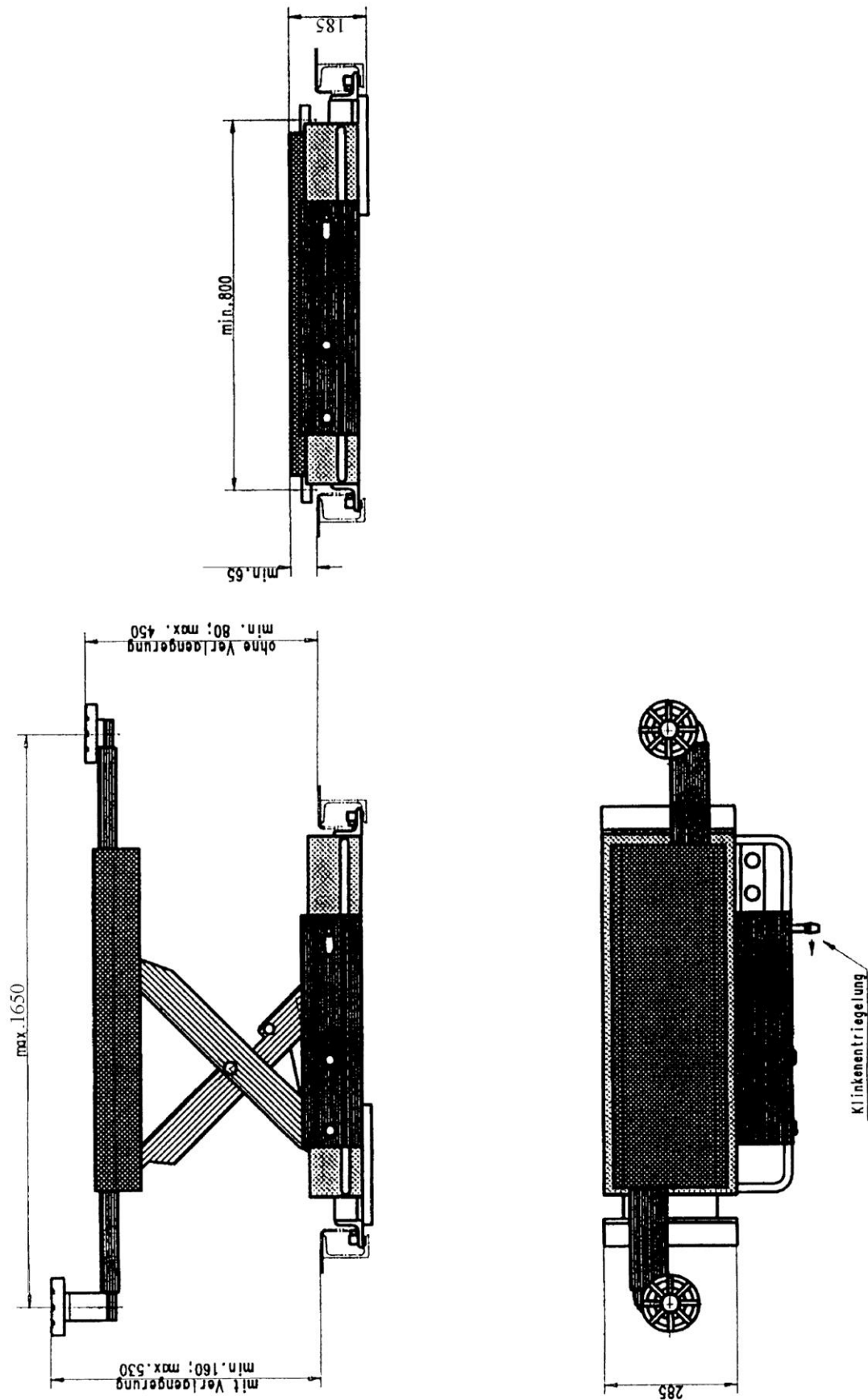

3.4 Hydraulic-Pneumatic diagram

Customer Installation requirements:
Air line with coupling (diameter width 6mm)
Air power supply 6-10 bar
Air: Anhydrous and oiled

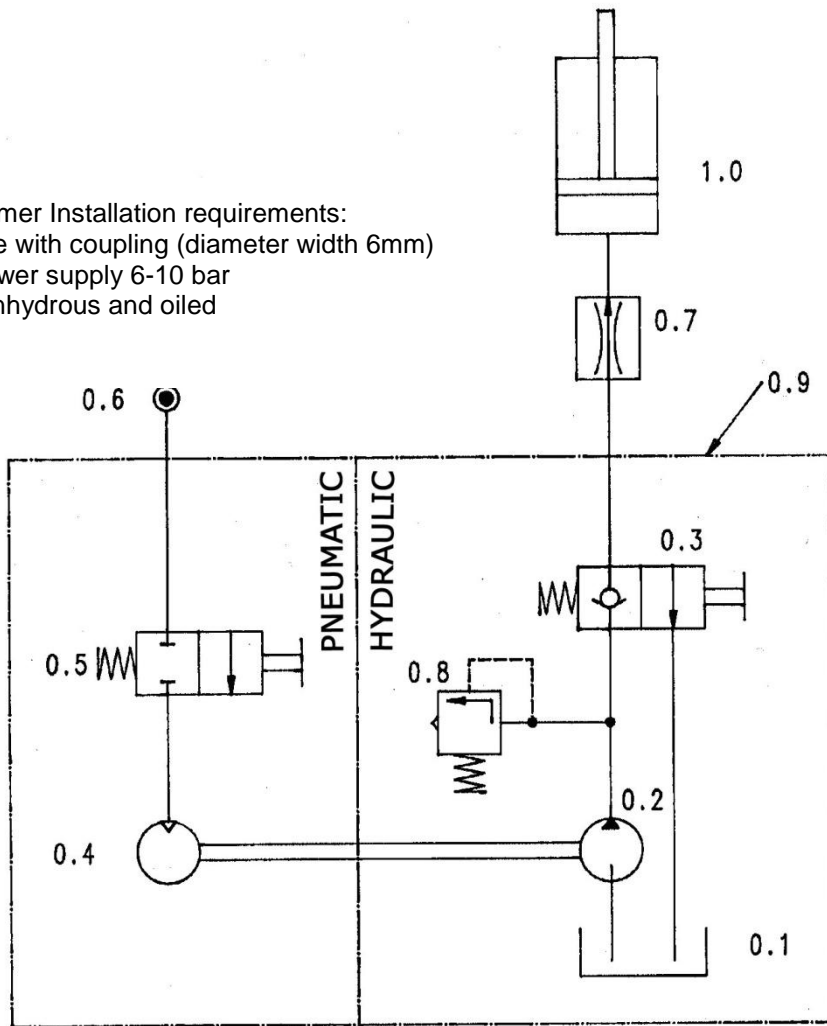

Parts list

No.	Description
0.1	Oil Tank
0.2	Hydraulic pump
0.3	Hydraulic valve
0.4	Pneumatic motor
0.5	Pneumatic valve
0.6	air pressure supply
0.7	lowering valve
0.8	pressure relief valve
0.9	air-hydraulic pump complete
1.0	Hydraulic cylinder

4. Safety regulations

The following regulations are very important:

- The laden weight of the lifted vehicle must not exceed 2000kg
- When the axle lift is working the operating instructions must be followed
- Only trained personnel over the age of 18 years old are to operate this axle lift
- The operator must observe the vehicle when it is lifted or lowered
- Only the operator is permitted to remain under the lifted or lowered vehicle
- It is not permitted to transport passengers on the axle lift or in the vehicle
- It is not permitted to climb onto the axle lift during lifting or lowering or onto a lifted vehicle
- The Axle Lift must be checked from an expert after changes in construction or after repairing carrying parts or pads.
- Care should be taken with vehicles with low sub-ground clearance or with optional equipment (sport equipment) or sport-vehicles. Previous damage to the types of vehicle should be noted before using this equipment.

5. Operating instructions



The Safety Regulations must be observed during working with the axle lift. Read the safety regulations in chapter 4 carefully before working with the lift!



Operation with the axle lift Jack CJB640 is only allowed with suitable water separator in the air supply, otherwise the axle lift can be damaged.

The operating elements are shown in picture 1

5.1 Lifting the vehicle

- Position the Jack under the pick-up-points which are described by the vehicle manufacturer.
- Block the vehicle against rolling, put into gear.
- Check the dangerous places of the lift and be sure that there are no objects or people in the immediate area of the lift or on the lift.
- Raise the lift. Press the button "Lifting".
- Stop the lifting, if the wheels are free. Check the safety position of the vehicle on the pads.
- Lift the vehicle on the working height. Press the button "Lifting" again.
- Observe the complete process.

pic 1: operating elements

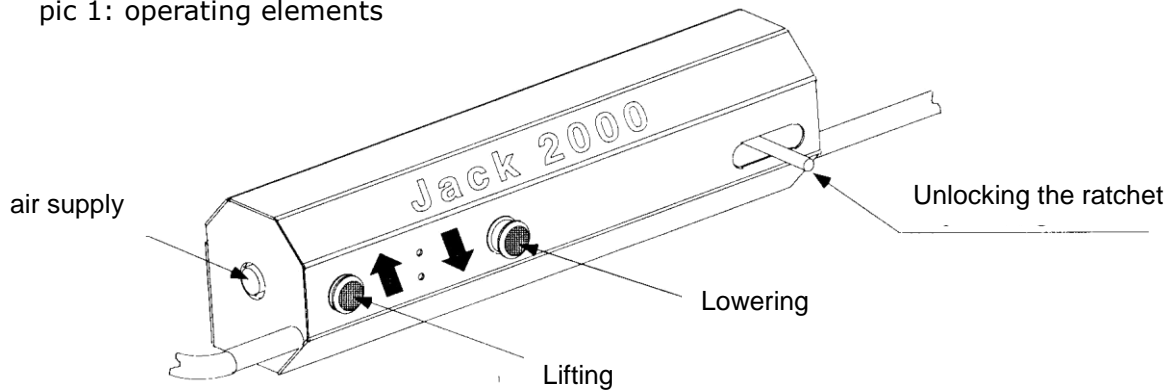

5.2 Lowering the Jack

- Check the dangerous places of the lift and be sure that there are no objects or people in the immediate area of the lift or on the lift.
- Unlock the ratchet; move lever for unlocking the ratchet to backside, tilt operating lever simultaneously to position "lowering" (see pic. 1) and lower vehicle to working height or to normal position on the drive-on rail.
- If the ratchet cannot be unlocked; press the lifting button until the ratchet is free. Afterwards unlock the ratchet; move lever for unlocking the ratchet backside.
- Lower vehicle to height for working or to normal position on the drive-on rail

6.Troubleshooting

If the lift does not work properly, the reason for this might be quite simple. Please check the lift for the potential reasons mentioned on the following pages. If the cause of trouble cannot be found, please call the Product Support Helpline.

Problem: the pump does not work

- Potential causes:*
- the pneumatic line defective

Problem: the pump starts, but the Jack does not lift

- Potential causes:*
- level of the hydraulic oil is too low
 - vehicle is too heavy
 - air pressure is too low

Problem: Jack can not be lowered

- Potential causes:*
- Jack is on an obstacle
 - Ratchet is locked

7. Inspection and Maintenance



Before conducting maintenance work, preparations must be made to ensure that during maintenance and repair work there is no risk to the safety of people working on or around the lift and also that there is no risk of damage to equipment being used on or around the lift.

To guarantee to ensure that the lift remains functional routine maintenance work contracts should be organised through our Product Support Helpline who can be contacted on the following number Tel: +44(0)844 665 7610 Fax: +44(0)844 7604 A service must be performed at regular intervals of 3 months through the operator in accordance with following maintenance plan. If the lift is in continuous operation or in a dirty environment, the maintenance rate must be increased.

During daily operation the lift must be closely observed to ensure that it is functioning correctly. In the case of malfunction or leakage please call the Product Support Helpline.

7.1 Maintenance plan of the lift

- Before beginning any maintenance work isolate the power supply. Secure the main switch (lock it). Secure the danger area around the axle lift and secure the lift against unintentional lowering.
- Clean the piston-rod and the stripper by using compressed air.
- Grease the lubricate nipples with a multipurpose lipid. (example: Auto Top 2000 LTD. Agip).
- Clean and lubricate the moving parts of the lift (hinge bolts, sliding pieces, sliding surfaces) grease with a multipurpose lipid (example: Auto Top 2000 LTD. Agip).
- Check the hydraulic tubes for leakage.
- Check the oil level. Fill the tank with a clean, high quality oil (32 cst) (e.g.g. HLP 32 LTD. OEST Company)
- The hydraulic oil has to be changed at least once a year. To change the oil, lower the lift into its lowest position. Empty all tanks and refill with clean oil, approx. 0,6 litres per hydraulic pump are needed.
Use an ATF-Suffix hydraulic-oil (OEST Company) if the ambient temperature is under 5 degrees centigrade. After filling, the hydraulic oil must be between the upper and lower markings of the oil level gauge.
Remove the old oil according to the appropriate regulations.
- Check all welded joints for cracks on the axle-lift.
If any cracks are found on the lift cease use immediately. Switch-off and secure the main switch (lock) and call the service partner.
- Check all surfaces and repair if necessary.
- Damage to external surfaces, must be immediately repaired.
If these repairs are not made immediately, permanent damage to the powder-coated surface may result.
Repair and clean damaged areas with an abrasive paper (grain 120). After this is complete, use a suitable paint (observe the RAL Number).
- Check the zinc surface and repair it with a suitable tool. Use abrasive paper (grain 280).

White rust can result from moisture laying in certain areas for long periods of time. Poor aerating can also result in rust formation.

Rust may result from mechanical damage, wear, aggressive sediments (de-icing salt, liquids) or insufficient cleaning.

Repair and clean these areas with abrasive paper (grain 280).

After this is complete, use a suitable paint (observe the RAL Number).

- Check all the safety devices of the axle lift. (ratchet)
- Check that all screws and bolts are correctly torque (turning moments, see the list Pic. 19)

Turning moment for screws

property class 8.8

property class 10.9

	0,10*	0,15**	0,20***
M8	20	25	30
M10	40	50	60
M12	69	87	105
M16	170	220	260
M20	340	430	520
M24	590	740	890

	0,10*	0,15**	0,20***
M8	30	37	44
M10	59	73	87
M12	100	125	151
M16	250	315	380
M20	490	615	740
M24	840	1050	1250

Drehmomenttabelle 8.8-10.9 E

- * sliding friction 0,10 for very good surfaces, lubricated
- ** sliding friction 0,15 for good surfaces, lubricated oder dry
- *** sliding friction 0,20 surface black or phosphatized, dry

pic 4:

7.2 How often must the lift be cleaned?

A regular and appropriate maintenance practice will aid the preservation of the Jack.

No guarantees can be given when damage (e.g rust or fading colour) is the direct result of poor maintenance and cleaning practice.

Regular cleaning of all kinds of dirt is the best protection against wear and the formation of rust and will prolong the life of the lift

- Dirty deposits that can cause rust include:

- de-icing salt
- Sand, pebble stone, natural soil
- all types of industrial dust
- Water; also in connection with other environmental influences
- All types of aggressive deposits
- Constant humidity caused by insufficient ventilation

Obviously this is dependent on the type of work being done with the lift, the degree of cleanliness of the workshop and location of the lift. The degree and amount of dirt is dependent on the season, on the weather conditions and the ventilation of the workshop.

During poor conditions it may be necessary to clean the lift once week, but cleaning once a month will suffice.

Clean the lift and the floor with a non-aggressive and non-abrasive detergent. Use a gentle detergent to clean the parts. Use an standard washing-up liquid and lukewarm water.

- Do not use steam jet cleaners.
- Remove all dirt carefully with a sponge or if necessary with a brush.
- Ensure that no washing-up liquid is left on the Jack after cleaning.
- Do not use aggressive means for cleaning the workshop floor and the Jack.
- A permanent contact with any kind of liquid is not allowed. Do not use high pressure devices for cleaning the Jack.

8. Security check

The security check is necessary to guarantee the safety of the lifting during use. It has to be performed in the following cases:

1. Before the initial operation, after the first installation
Use the form "First security check before initiation"
2. In regular intervals after the initial operation, at least annually.
Use the form "Regular security check at least annually"
3. Every time the construction of that particular lift has been changed.
Use the form "Extraordinary security check"



The first and the regular security check must be performed by a competent person. It is recommended to service the lift at this occasion.



After the construction of the lift has been changed (changing the lifting height or capacity for example) and after serious maintenance work (welding on carrying parts) an extraordinary security check must be performed by an expert.

This manual contains form with a schedule for the security checks. Please use the correct form for the security checks. The form should remain in this manual after they have been filled out. In the following there is a short description about special safety devices.

9. Installation

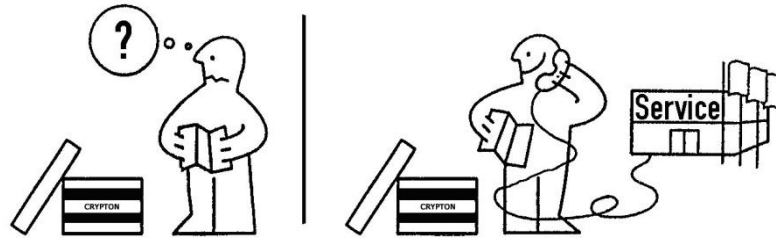

9.1 Regulations of installation

- The axle lift is mounted between the drive-on rails of an automotive lift.
- Use axle lift only with the approved automotive lift.
(difference between drive-on rails: The distance can vary upon types)
- The installation of the axle lift is performed by trained technicians of the manufacturer or its distribution partner. If the operator can provide trained mechanics, he can install the axle lift by himself. The installation has to be done according to this regulation.
- A compressed air supply with an inside width of 6 mm has to be provided at the command unit. The pressure must be min. 6 bar - max. 10 bar.
- Pull out guide wheels of axle lift to required measurement (depending on installation data of automotive lift)
- Push axle lift in drive-on rail. Install limit stops at ends of drive-on rails to avoid axle lift falling out of the automotive axle lift.
- Insert pads in carrying arms
- Connect air supply with the axle lift

9.2 Initiation



Before the initiation a security check must be performed. Therefore use form: First security check.

If the axle lift is installed by a competent person, he will perform this security check. If the operator installs the axle lift by himself, he has to instruct a competent person to perform the security check.

The competent person confirms the correct operation of the axle lift in the installation record, completes the security check and allows the axle lift to be used.



Please send the filled installation record to the manufacturer after installation.

9.3 Changing the installation place

If the place of installation shall be changed, the new place has to be prepared according to these regulations. The changing of the location must be performed according to the following schedule:



Instructions and Documentation Crypton Jacking Beam Class 4

- Take off pads from carrying arms.
- Lower axle lift to lowest position.
- Loosen pneumatic lines.
- Take off limit stops at the ends of the drive-on rails and pull out axle lift.
- Transport axle lift to its new location.
- Install axle lift according to first installation of the axle lift.



A security check must be performed before reinitiating by a competent person. Use form "Regular security check".



First security check before installation



Complete and leave in this manual

Serial-number: _____

	Pass	Fail	Verified	remark
Type plate.....	<input type="checkbox"/>	<input type="checkbox"/>	<input type="checkbox"/>
Short operating instruction.....	<input type="checkbox"/>	<input type="checkbox"/>	<input type="checkbox"/>
Warning designation.....	<input type="checkbox"/>	<input type="checkbox"/>	<input type="checkbox"/>
Sticker "max. capacity".....	<input type="checkbox"/>	<input type="checkbox"/>	<input type="checkbox"/>
Function, Condition safety ratchet.....	<input type="checkbox"/>	<input type="checkbox"/>	<input type="checkbox"/>
Function lifting/lowering.....	<input type="checkbox"/>	<input type="checkbox"/>	<input type="checkbox"/>
Detailed operating instruction.....	<input type="checkbox"/>	<input type="checkbox"/>	<input type="checkbox"/>
Safety device of hinge bolt.....	<input type="checkbox"/>	<input type="checkbox"/>	<input type="checkbox"/>
Condition colour.....	<input type="checkbox"/>	<input type="checkbox"/>	<input type="checkbox"/>
Construction (deformation, cracking)	<input type="checkbox"/>	<input type="checkbox"/>	<input type="checkbox"/>
Torque moments of the screws	<input type="checkbox"/>	<input type="checkbox"/>	<input type="checkbox"/>
Condition operating unit.....	<input type="checkbox"/>	<input type="checkbox"/>	<input type="checkbox"/>
Condition surface piston rod.....	<input type="checkbox"/>	<input type="checkbox"/>	<input type="checkbox"/>
Condition coverings.....	<input type="checkbox"/>	<input type="checkbox"/>	<input type="checkbox"/>
Level of hydraulic oil	<input type="checkbox"/>	<input type="checkbox"/>	<input type="checkbox"/>
Closeness of the hydraulic system.....	<input type="checkbox"/>	<input type="checkbox"/>	<input type="checkbox"/>
Condition hydraulic hoses.....	<input type="checkbox"/>	<input type="checkbox"/>	<input type="checkbox"/>
Function test with vehicle.....	<input type="checkbox"/>	<input type="checkbox"/>	<input type="checkbox"/>
Guidance axle lift between rails.....	<input type="checkbox"/>	<input type="checkbox"/>	<input type="checkbox"/>
Condition welding.....	<input type="checkbox"/>	<input type="checkbox"/>	<input type="checkbox"/>
Condition pneumatic lines.....	<input type="checkbox"/>	<input type="checkbox"/>	<input type="checkbox"/>
Condition rubber supports	<input type="checkbox"/>	<input type="checkbox"/>	<input type="checkbox"/>

(mark here applicable, in case of verification mark in addition to the first mark!)

Security check carried out:.....

Carried out the company:.....

Name, address of the competent:.....

Result of the Check:

- Initiation not permitted, verification necessary
- Initiation possible, repair failures until.....
- No failings, Initiation possible

.....
signature of the expert

.....
signature of the operator

If failures must be repaired:

Failures repaired at:

.....signature of the operator

(Use another form for verification!)



First security check before installation



Complete and leave in this manual

Serial-number: _____

	Pass	Fail	Verified	remark
Type plate.....	<input type="checkbox"/>	<input type="checkbox"/>	<input type="checkbox"/>
Short operating instruction.....	<input type="checkbox"/>	<input type="checkbox"/>	<input type="checkbox"/>
Warning designation.....	<input type="checkbox"/>	<input type="checkbox"/>	<input type="checkbox"/>
Sticker "max. capacity".....	<input type="checkbox"/>	<input type="checkbox"/>	<input type="checkbox"/>
Function, Condition safety ratchet.....	<input type="checkbox"/>	<input type="checkbox"/>	<input type="checkbox"/>
Function lifting/lowering.....	<input type="checkbox"/>	<input type="checkbox"/>	<input type="checkbox"/>
Detailed operating instruction.....	<input type="checkbox"/>	<input type="checkbox"/>	<input type="checkbox"/>
Safety device of hinge bolt.....	<input type="checkbox"/>	<input type="checkbox"/>	<input type="checkbox"/>
Condition colour.....	<input type="checkbox"/>	<input type="checkbox"/>	<input type="checkbox"/>
Construction (deformation, cracking)	<input type="checkbox"/>	<input type="checkbox"/>	<input type="checkbox"/>
Torque moments of the screws	<input type="checkbox"/>	<input type="checkbox"/>	<input type="checkbox"/>
Condition operating unit.....	<input type="checkbox"/>	<input type="checkbox"/>	<input type="checkbox"/>
Condition surface piston rod.....	<input type="checkbox"/>	<input type="checkbox"/>	<input type="checkbox"/>
Condition coverings.....	<input type="checkbox"/>	<input type="checkbox"/>	<input type="checkbox"/>
Level of hydraulic oil	<input type="checkbox"/>	<input type="checkbox"/>	<input type="checkbox"/>
Closeness of the hydraulic system.....	<input type="checkbox"/>	<input type="checkbox"/>	<input type="checkbox"/>
Condition hydraulic hoses.....	<input type="checkbox"/>	<input type="checkbox"/>	<input type="checkbox"/>
Function test with vehicle.....	<input type="checkbox"/>	<input type="checkbox"/>	<input type="checkbox"/>
Guidance axle lift between rails.....	<input type="checkbox"/>	<input type="checkbox"/>	<input type="checkbox"/>
Condition welding.....	<input type="checkbox"/>	<input type="checkbox"/>	<input type="checkbox"/>
Condition pneumatic lines.....	<input type="checkbox"/>	<input type="checkbox"/>	<input type="checkbox"/>
Condition rubber supports	<input type="checkbox"/>	<input type="checkbox"/>	<input type="checkbox"/>

(mark here applicable, in case of verification mark in addition to the first mark!)

Security check carried out:.....

Carried out the company:.....

Name, address of the competent:.....

Result of the Check:

- Initiation not permitted, verification necessary
- Initiation possible, repair failures until.....
- No failings, Initiation possible

.....
signature of the expert

.....
signature of the operator

If failures must be repaired:

Failures repaired at:

.....signature of the operator

(Use another form for verification!)



First security check before installation



Complete and leave in this manual

Serial-number: _____

	Pass	Fail	Verified	remark
Type plate.....	<input type="checkbox"/>	<input type="checkbox"/>	<input type="checkbox"/>
Short operating instruction.....	<input type="checkbox"/>	<input type="checkbox"/>	<input type="checkbox"/>
Warning designation.....	<input type="checkbox"/>	<input type="checkbox"/>	<input type="checkbox"/>
Sticker "max. capacity".....	<input type="checkbox"/>	<input type="checkbox"/>	<input type="checkbox"/>
Function, Condition safety ratchet.....	<input type="checkbox"/>	<input type="checkbox"/>	<input type="checkbox"/>
Function lifting/lowering.....	<input type="checkbox"/>	<input type="checkbox"/>	<input type="checkbox"/>
Detailed operating instruction.....	<input type="checkbox"/>	<input type="checkbox"/>	<input type="checkbox"/>
Safety device of hinge bolt.....	<input type="checkbox"/>	<input type="checkbox"/>	<input type="checkbox"/>
Condition colour.....	<input type="checkbox"/>	<input type="checkbox"/>	<input type="checkbox"/>
Construction (deformation, cracking)	<input type="checkbox"/>	<input type="checkbox"/>	<input type="checkbox"/>
Torque moments of the screws	<input type="checkbox"/>	<input type="checkbox"/>	<input type="checkbox"/>
Condition operating unit.....	<input type="checkbox"/>	<input type="checkbox"/>	<input type="checkbox"/>
Condition surface piston rod.....	<input type="checkbox"/>	<input type="checkbox"/>	<input type="checkbox"/>
Condition coverings.....	<input type="checkbox"/>	<input type="checkbox"/>	<input type="checkbox"/>
Level of hydraulic oil	<input type="checkbox"/>	<input type="checkbox"/>	<input type="checkbox"/>
Closeness of the hydraulic system.....	<input type="checkbox"/>	<input type="checkbox"/>	<input type="checkbox"/>
Condition hydraulic hoses.....	<input type="checkbox"/>	<input type="checkbox"/>	<input type="checkbox"/>
Function test with vehicle.....	<input type="checkbox"/>	<input type="checkbox"/>	<input type="checkbox"/>
Guidance axle lift between rails.....	<input type="checkbox"/>	<input type="checkbox"/>	<input type="checkbox"/>
Condition welding.....	<input type="checkbox"/>	<input type="checkbox"/>	<input type="checkbox"/>
Condition pneumatic lines.....	<input type="checkbox"/>	<input type="checkbox"/>	<input type="checkbox"/>
Condition rubber supports	<input type="checkbox"/>	<input type="checkbox"/>	<input type="checkbox"/>

(mark here applicable, in case of verification mark in addition to the first mark!)

Security check carried out:.....

Carried out the company:.....

Name, address of the competent:.....

Result of the Check:

- Initiation not permitted, verification necessary
- Initiation possible, repair failures until.....
- No failings, Initiation possible

.....
signature of the expert

.....
signature of the operator

If failures must be repaired:

Failures repaired at:

.....signature of the operator

(Use another form for verification!)



First security check before installation



Complete and leave in this manual

Serial-number: _____

	Pass	Fail	Verified	remark
Type plate.....	<input type="checkbox"/>	<input type="checkbox"/>	<input type="checkbox"/>
Short operating instruction.....	<input type="checkbox"/>	<input type="checkbox"/>	<input type="checkbox"/>
Warning designation.....	<input type="checkbox"/>	<input type="checkbox"/>	<input type="checkbox"/>
Sticker "max. capacity".....	<input type="checkbox"/>	<input type="checkbox"/>	<input type="checkbox"/>
Function, Condition safety ratchet.....	<input type="checkbox"/>	<input type="checkbox"/>	<input type="checkbox"/>
Function lifting/lowering.....	<input type="checkbox"/>	<input type="checkbox"/>	<input type="checkbox"/>
Detailed operating instruction.....	<input type="checkbox"/>	<input type="checkbox"/>	<input type="checkbox"/>
Safety device of hinge bolt.....	<input type="checkbox"/>	<input type="checkbox"/>	<input type="checkbox"/>
Condition colour.....	<input type="checkbox"/>	<input type="checkbox"/>	<input type="checkbox"/>
Construction (deformation, cracking)	<input type="checkbox"/>	<input type="checkbox"/>	<input type="checkbox"/>
Torque moments of the screws	<input type="checkbox"/>	<input type="checkbox"/>	<input type="checkbox"/>
Condition operating unit.....	<input type="checkbox"/>	<input type="checkbox"/>	<input type="checkbox"/>
Condition surface piston rod.....	<input type="checkbox"/>	<input type="checkbox"/>	<input type="checkbox"/>
Condition coverings.....	<input type="checkbox"/>	<input type="checkbox"/>	<input type="checkbox"/>
Level of hydraulic oil	<input type="checkbox"/>	<input type="checkbox"/>	<input type="checkbox"/>
Closeness of the hydraulic system.....	<input type="checkbox"/>	<input type="checkbox"/>	<input type="checkbox"/>
Condition hydraulic hoses.....	<input type="checkbox"/>	<input type="checkbox"/>	<input type="checkbox"/>
Function test with vehicle.....	<input type="checkbox"/>	<input type="checkbox"/>	<input type="checkbox"/>
Guidance axle lift between rails.....	<input type="checkbox"/>	<input type="checkbox"/>	<input type="checkbox"/>
Condition welding.....	<input type="checkbox"/>	<input type="checkbox"/>	<input type="checkbox"/>
Condition pneumatic lines.....	<input type="checkbox"/>	<input type="checkbox"/>	<input type="checkbox"/>
Condition rubber supports	<input type="checkbox"/>	<input type="checkbox"/>	<input type="checkbox"/>

(mark here applicable, in case of verification mark in addition to the first mark!)

Security check carried out:.....

Carried out the company:.....

Name, address of the competent:.....

Result of the Check:

- Initiation not permitted, verification necessary
- Initiation possible, repair failures until.....
- No failings, Initiation possible

.....
signature of the expert

.....
signature of the operator

If failures must be repaired:

Failures repaired at:

.....signature of the operator

(Use another form for verification!)



First security check before installation



Complete and leave in this manual

Serial-number: _____

	Pass	Fail	Verified	remark
Type plate.....	<input type="checkbox"/>	<input type="checkbox"/>	<input type="checkbox"/>
Short operating instruction.....	<input type="checkbox"/>	<input type="checkbox"/>	<input type="checkbox"/>
Warning designation.....	<input type="checkbox"/>	<input type="checkbox"/>	<input type="checkbox"/>
Sticker "max. capacity".....	<input type="checkbox"/>	<input type="checkbox"/>	<input type="checkbox"/>
Function, Condition safety ratchet.....	<input type="checkbox"/>	<input type="checkbox"/>	<input type="checkbox"/>
Function lifting/lowering.....	<input type="checkbox"/>	<input type="checkbox"/>	<input type="checkbox"/>
Detailed operating instruction.....	<input type="checkbox"/>	<input type="checkbox"/>	<input type="checkbox"/>
Safety device of hinge bolt.....	<input type="checkbox"/>	<input type="checkbox"/>	<input type="checkbox"/>
Condition colour.....	<input type="checkbox"/>	<input type="checkbox"/>	<input type="checkbox"/>
Construction (deformation, cracking)	<input type="checkbox"/>	<input type="checkbox"/>	<input type="checkbox"/>
Torque moments of the screws	<input type="checkbox"/>	<input type="checkbox"/>	<input type="checkbox"/>
Condition operating unit.....	<input type="checkbox"/>	<input type="checkbox"/>	<input type="checkbox"/>
Condition surface piston rod.....	<input type="checkbox"/>	<input type="checkbox"/>	<input type="checkbox"/>
Condition coverings.....	<input type="checkbox"/>	<input type="checkbox"/>	<input type="checkbox"/>
Level of hydraulic oil	<input type="checkbox"/>	<input type="checkbox"/>	<input type="checkbox"/>
Closeness of the hydraulic system.....	<input type="checkbox"/>	<input type="checkbox"/>	<input type="checkbox"/>
Condition hydraulic hoses.....	<input type="checkbox"/>	<input type="checkbox"/>	<input type="checkbox"/>
Function test with vehicle.....	<input type="checkbox"/>	<input type="checkbox"/>	<input type="checkbox"/>
Guidance axle lift between rails.....	<input type="checkbox"/>	<input type="checkbox"/>	<input type="checkbox"/>
Condition welding.....	<input type="checkbox"/>	<input type="checkbox"/>	<input type="checkbox"/>
Condition pneumatic lines.....	<input type="checkbox"/>	<input type="checkbox"/>	<input type="checkbox"/>
Condition rubber supports	<input type="checkbox"/>	<input type="checkbox"/>	<input type="checkbox"/>

(mark here applicable, in case of verification mark in addition to the first mark!)

Security check carried out:.....

Carried out the company:.....

Name, address of the competent:.....

Result of the Check:

- Initiation not permitted, verification necessary
- Initiation possible, repair failures until.....
- No failings, Initiation possible

.....
signature of the expert

.....
signature of the operator

If failures must be repaired:

Failures repaired at:

.....signature of the operator

(Use another form for verification!)



First security check before installation



Complete and leave in this manual

Serial-number: _____

	Pass	Fail	Verified	remark
Type plate.....	<input type="checkbox"/>	<input type="checkbox"/>	<input type="checkbox"/>
Short operating instruction.....	<input type="checkbox"/>	<input type="checkbox"/>	<input type="checkbox"/>
Warning designation.....	<input type="checkbox"/>	<input type="checkbox"/>	<input type="checkbox"/>
Sticker "max. capacity".....	<input type="checkbox"/>	<input type="checkbox"/>	<input type="checkbox"/>
Function, Condition safety ratchet.....	<input type="checkbox"/>	<input type="checkbox"/>	<input type="checkbox"/>
Function lifting/lowering.....	<input type="checkbox"/>	<input type="checkbox"/>	<input type="checkbox"/>
Detailed operating instruction.....	<input type="checkbox"/>	<input type="checkbox"/>	<input type="checkbox"/>
Safety device of hinge bolt.....	<input type="checkbox"/>	<input type="checkbox"/>	<input type="checkbox"/>
Condition colour.....	<input type="checkbox"/>	<input type="checkbox"/>	<input type="checkbox"/>
Construction (deformation, cracking)	<input type="checkbox"/>	<input type="checkbox"/>	<input type="checkbox"/>
Torque moments of the screws	<input type="checkbox"/>	<input type="checkbox"/>	<input type="checkbox"/>
Condition operating unit.....	<input type="checkbox"/>	<input type="checkbox"/>	<input type="checkbox"/>
Condition surface piston rod.....	<input type="checkbox"/>	<input type="checkbox"/>	<input type="checkbox"/>
Condition coverings.....	<input type="checkbox"/>	<input type="checkbox"/>	<input type="checkbox"/>
Level of hydraulic oil	<input type="checkbox"/>	<input type="checkbox"/>	<input type="checkbox"/>
Closeness of the hydraulic system.....	<input type="checkbox"/>	<input type="checkbox"/>	<input type="checkbox"/>
Condition hydraulic hoses.....	<input type="checkbox"/>	<input type="checkbox"/>	<input type="checkbox"/>
Function test with vehicle.....	<input type="checkbox"/>	<input type="checkbox"/>	<input type="checkbox"/>
Guidance axle lift between rails.....	<input type="checkbox"/>	<input type="checkbox"/>	<input type="checkbox"/>
Condition welding.....	<input type="checkbox"/>	<input type="checkbox"/>	<input type="checkbox"/>
Condition pneumatic lines.....	<input type="checkbox"/>	<input type="checkbox"/>	<input type="checkbox"/>
Condition rubber supports	<input type="checkbox"/>	<input type="checkbox"/>	<input type="checkbox"/>

(mark here applicable, in case of verification mark in addition to the first mark!)

Security check carried out:.....

Carried out the company:.....

Name, address of the competent:.....

Result of the Check:

- Initiation not permitted, verification necessary
- Initiation possible, repair failures until.....
- No failings, Initiation possible

.....
signature of the expert

.....
signature of the operator

If failures must be repaired:

Failures repaired at:signature of the operator

(Use another form for verification!)



AFTER SALES SERVICE

Apart from the routine maintenance and adjustments stipulated in this manual the equipment must not be tampered with in any way. All further servicing must be carried out only by an engineer from an Authorised Agent. Failure to observe these conditions will invalidate the Guarantee.
On-Site Service / Overhaul / Spare Parts

For customers in the UK:

If you require a Service Engineer to attend ON SITE, either due to an equipment fault, or for machine calibration, or if the equipment covered by this manual requires to be sent back for factory overhaul, or if you need spare parts, please contact our Product Support Helpline at the following numbers.

Tel: +44(0)844 665 7610

Fax: +44(0)844 665 7604

Email: support@cryptontechnology.com

Overseas customers:

Service abroad is provided by the agent from whom your equipment was purchased.

Technical Information

Crypton provide information and contracts covering:

Car Data, Fault Code Information, Diagnostic Information, Software Support Contracts, Software Updates & Accessories.

Crypton Ltd. Hopton Industrial Estate, London Road, Devizes, Wiltshire, SN10 2EU

Tel: +44 (0) 844 665 7613

Fax: +44 (0) 844 665 7604

Email: sales@cryptontechnology.com

Website: www.cryptontechnology.com